

## Bookshelves, Regale, Bibliothèque, Estanterias.

design Angelo Mangiarotti, 1973

### Libreria in marmo per interno

Marble Bookshelf for indoor

ALICL2575 / ALICC2575/ ALICR35200/

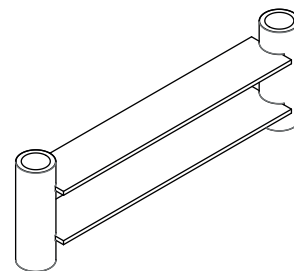

H. 75  
(29" 17/32)

ALIC2575

ø25 (9" 27/32)

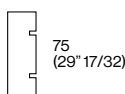

gamba/leg kg. 46

ALICC2575

ø25 (9" 27/32)

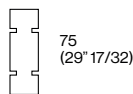

gamba/leg kg. 45

ALICR35200

200 (78" 47/64)



piano/top kg. 57

### Composizione singola Single composition

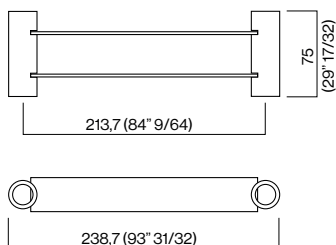

### Composizione multipla Multiple composition

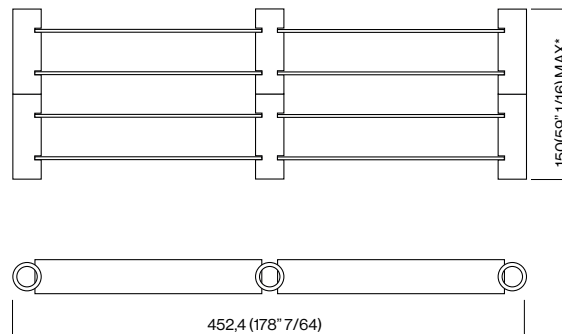

Personale consigliato per movimentare  
gli articoli / Recommended staff to  
handle the items



Rimane a discrezione dell'esecutore/installatore di applicare la normativa vigente nel proprio paese per la movimentazione dei carichi  
It's up to the installer to adhere to the prescriptions/regulations existing in his country for the handling of heavy goods

# Cura e Manutenzione

## Maintenance and Care.

Libreria Loico  
Loico Bookshelf

design Angelo Mangiarotti, 1973

### **Per superfici levigate e opache:**

Si consiglia la manutenzione ordinaria di questi prodotti con il prodotto "Filarefresh", detergente protettivo. Utilizzato quotidianamente deterge le superfici e rafforza il trattamento protettivo antimacchia.

Prodotto neutro ideale anche per le superfici in pietra naturale più delicate. (Facile da usare, pronto all'uso, non necessita di risciacquo, rapida asciugatura, profumazione gradevole e certificato per il contatto alimentare).

Applicazione: Spruzzare Filarefresh sulla superficie e passare con un panno morbido e asciutto, massaggiare la superficie fino a completa asciugatura. Non risciacquare.

### **Per superfici lucide:**

La manutenzione ordinaria di questi prodotti va fatta con detersivi neutri, intervallando l'utilizzo di "Formula marmo", crema polish per marmo di Fila. Questo prodotto, pronto all'uso, protegge e pulisce le piccole superfici in marmo, rimuove i residui calcarei lasciati dall'acqua e restituisce brillantezza alle superfici lucide consumate.

Applicazione: Agitare prima dell'uso. Versare su un panno e passare sulla superficie da pulire. Insistere per pochi secondi fino alla completa asciugatura.

### **For smooth and opaque surfaces:**

*We recommend routine maintenance of these products with the product "Filarefresh" protective detergent. For daily use, it cleans the surfaces and strengthens stain-resistant treatment.*

*It's a neutral product also ideal for delicate natural stone surfaces. (Easy to use, ready to use, no rinse, quick drying, pleasing scent and certified for food contact).*

Application: *Spray Filarefresh on the surface and pass with a soft, dry cloth, massage the surface until completely dry. Do not rinse.*

### **For shiny surfaces:**

*Ordinary maintenance of these products has to be done with neutral detergents, employing every now and then "Marble Formula", a polish cream for marble by Fila. This product, ready to use, protects and cleans the small marble surfaces, removes the limestone residues left by the water and gives back shining effect to the marble surfaces.*

Application: *Shake before using. Pour on a cloth and pass on the surface to be cleaned. Insist for a few seconds until fully dry.*



Tutti i prodotti Agapecasa sono progettati e realizzati per uso interno. Non possono essere collocati all'esterno se non diversamente indicato.

*All Agapecasa products are designed and manufactured for internal use. They cannot be placed outside unless otherwise indicated.*

# Istruzioni di Montaggio

## Assembly Instructions.

p. 3/6

Libreria Loico  
Loico Bookshelf

design Angelo Mangiarotti, 1973



Contenuto della confezione  
Package Contents

Strumenti necessari  
Required Tools

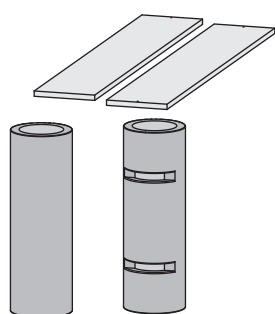

Fornito con composizioni multiple  
Provided with multiple compositions



Fornito con composizioni a più piani  
(1 pezzo ogni sostegno)  
Provided with multi-store  
compositions (1 piece for each support)

La quantità variano a seconda della composizione  
Quantities change depending on the composition

### 1. Posizionamento dei sostegni per composizione singola Placement of the supports for single composition



Per composizione singola i  
sostegni devono essere  
rivolti con i fori verso il basso

*In case of single composition  
the holes in the supports have  
to look downwards*

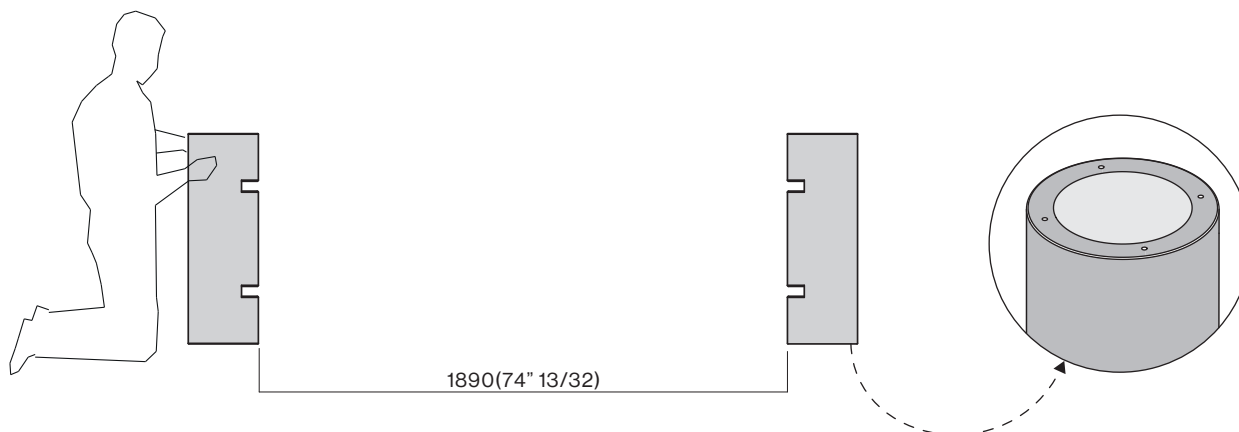

AGAPECASA

via A. Pitentino, 6  
46037 Governolo  
Roncoferraro  
Mantova - Italia

tel.+39 0376 250 311  
fax.+39 0376 250 330  
info@agapecasa.it  
agapecasa.it

### 2. Posizionamento dei ripiani

Placement of the shelves



Inserire ripiani nelle sedi dei sostegni

*Insert shelves into the seats of the supports*

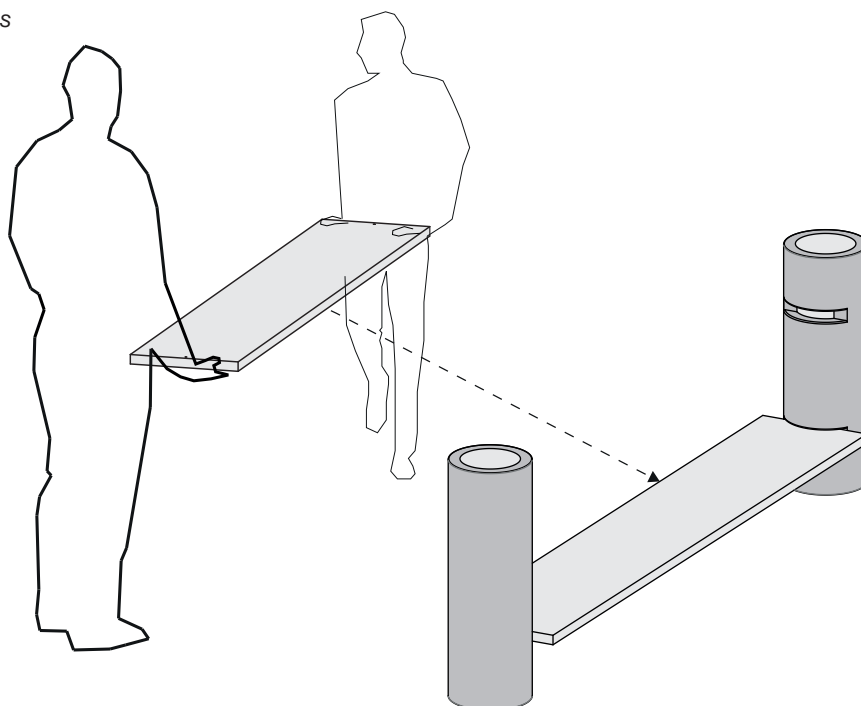

### 1. Posizionamento dei sostegni per composizione multipla

Placement of the supports for multiple composition



Per composizioni a più piani i sostegni devono essere rivolti con i fori verso l'alto

*In case of multi-storey compositions the holes in the supports have to look upwards*

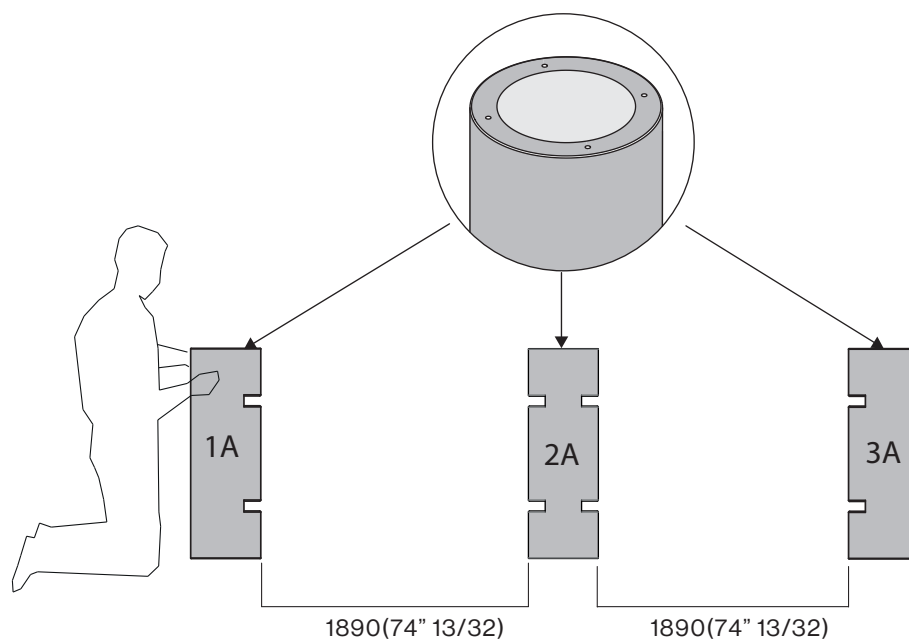

### 2. Posizionamento dei ripiani

Placement of the shelves



Inserire i ripiani nelle sedi dei sostegni seguendo i riferimenti indicati sui componenti, che devono corrispondere come in figura

*Insert the shelves in the supports, following the indicated references on the components, which must correspond as shown in the figure components*

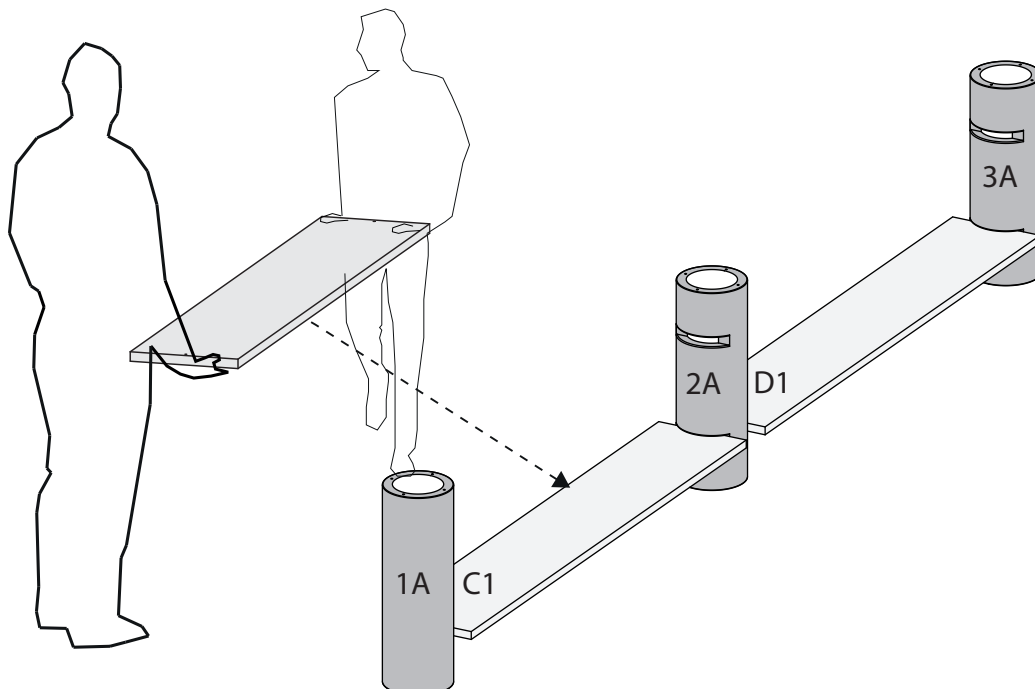

### 3.



Appoggiare l'anello di centraggio

*Place the centering ring*

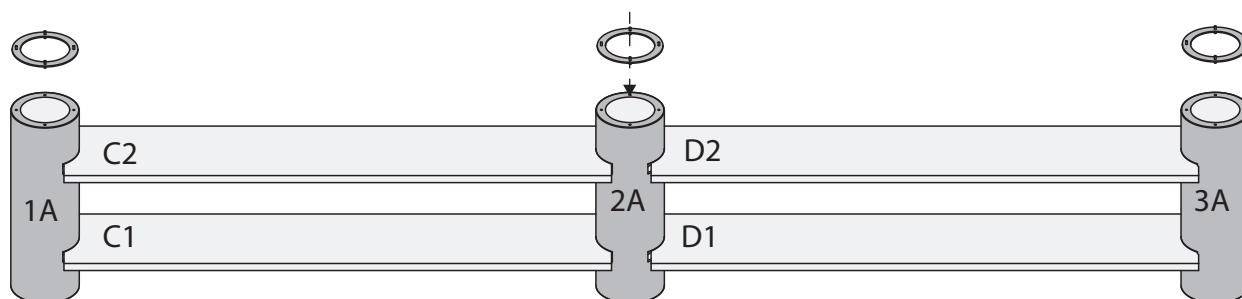

## 4.

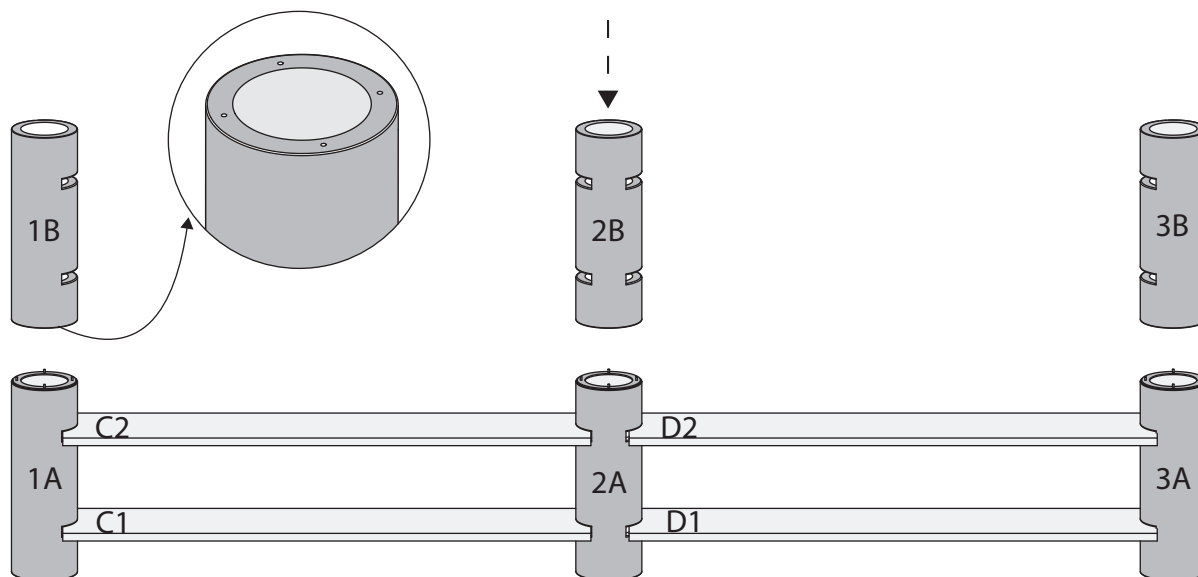

## 5.



Inserire i ripiani mancanti  
ripetendo il passaggio n°  
2

*Insert the missing shelves  
repeating step n° 2*

